



Metador

# Defender ModuleX

Defender ModuleX is designed to facilitate fitting flush into reduced depth wall panels as used in the modular building industry.



The Defender ModuleX doorset has been designed for the modular building industry to provide an ultimate fast-fitting and cost-effective solution complete with a four-sided cloaking frame.

The Defender ModuleX doorset is manufactured from 1.5mm galvanised steel with internal steel strengtheners as standard. Frames are 2mm galvanised steel and have 2mm stainless steel thresholds making the Defender Safeguard a longer lasting, stronger door. Also, it has a mineral wool core making it more thermal efficient than cardboard honeycomb infill versions.

The unique flange frame design efficiently seals the frame to the building whilst concealing panel cut outs.

## Door Leaf

Manufactured from two 1.5mm Galvanised steel skins, folded and mechanically fixed to form a strong and rigid 45mm thick door leaf, filled with internal steel strengtheners and mineral wool for ultimate insulation. Anti-jemmy flanges to the leading edge of the leaf provide excellent jemmy resistance.

## Frame

Both 68mm outward opening and 75mm inward opening frames are pressed from 1.5mm galvanised steel to form a single rebated and an in-built cloaking profile. Profile headers form a smooth butt joint with the vertical posts and are joined together utilising strong M8 bolts to provide positive rigidity. Complete with 8 fixing locations per doorset.

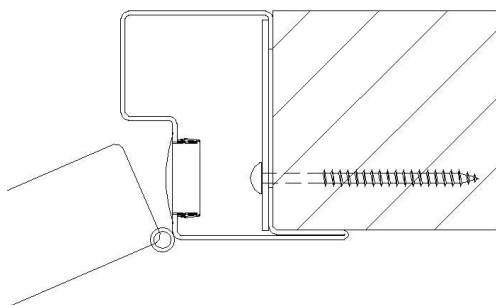

## Hardware

Door leaves are hung from 3 no stainless steel hinges for smooth operation and optimum weather resistance. Security dog bolts secure the leaf into the frame if the hinges are attacked. Operated by sashlock and lever handles.

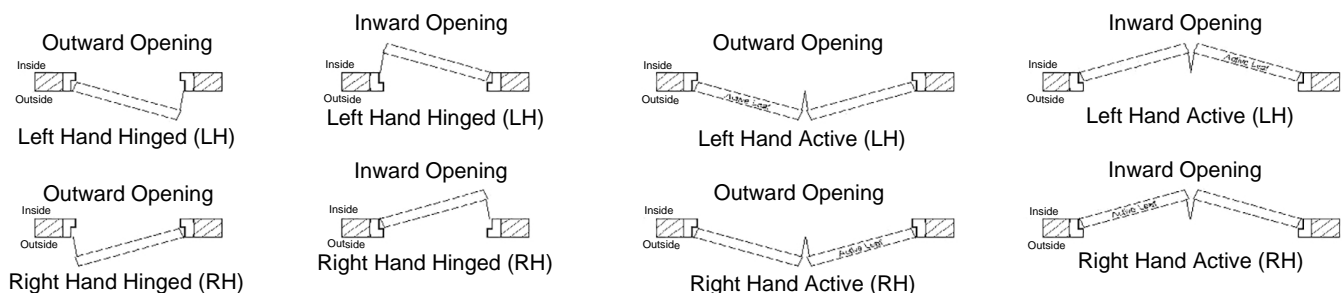

## Finish

Powder coated to any RAL or BS standard.

## Thresholds

DDA compliant 1.5mm stainless steel threshold bolted into the vertical frame posts. Available in inward or outward opening with full in-built cloaking to prevent water ingress into the floor of the building.

## Thermal Performance

Tested and achieving a rating of 2.2W/m<sup>2</sup>K based on a door size of 1090mm x 2090mm WxH\* - values may vary slightly depending on size and finished colour of doorset.

## Seal

For optimum weather, thermal and acoustic performance, an EPDM seal is bonded into the frame rebate to ensure effective sealing of the door/frame gap.

## Optional Extras

A large range of vision panels are available in various glass types and thicknesses. Louvre panels, closers and door restrictors, threaded frame adjuster fixing points and emergency exit panic ironmongery are available.

### Structural opening sizes (mm)\*\*

	Max width	Max height
Single leaf	1480	2950
Double leaf	2800	2950

\* As per third party accreditation testing by Ceribois (notified body number 2061) to European Standards EN 1007-1 and EN 13162 on 23rd March 2016.

\*\*For oversized doors, please enquire

**Made of stronger stuff.**

**Metador**  
 Britannia House, John Boyle Road,  
 Middlesbrough, TS6 6TY  
 T 01642 337119

Visit our website  
[www.metador.com](http://www.metador.com)